

DRAWING MADE BY  
**CAD**  
HAND MADE MODIFICATIONS ARE FORBIDDEN

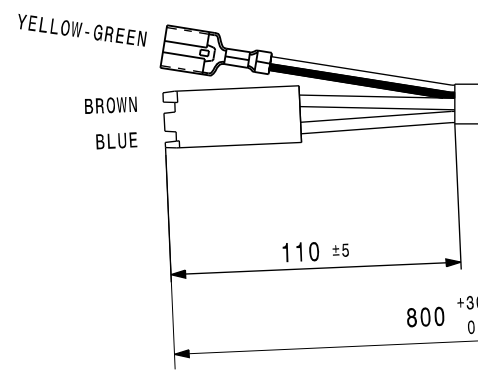

CLASS "B" MOTOR - SLEEVE BEARING MANUFACTURED ( Motore in Classe "B" - Esecuzione a Bronzine )	
AXIAL CLEARANCE ( Gioco Assiale )	0,5 - 2,5 mm
COVER - CABLE SIDE ( Coperchio Lato Cavi )	CLOSED ( Chiuso )
COVER - OPPOSITE CABLE SIDE ( Lato Opposto Cavi )	CLOSED ( Chiuso )
ASSEMBLY SPECIFICATION ( Normativa Note di Montaggio )	EL.UN.0002
MECHANICAL SPECIFICATION ( Normativa di Controllo Meccanico )	EL.CM.0001
ELECTRICAL SPECIFICATION ( Controllo Elettrico con Prescrizione N° )	M.2202/1

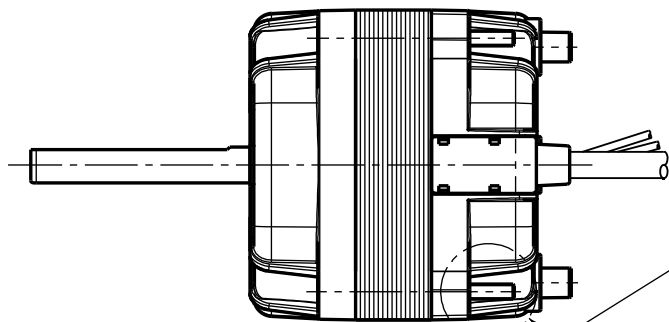
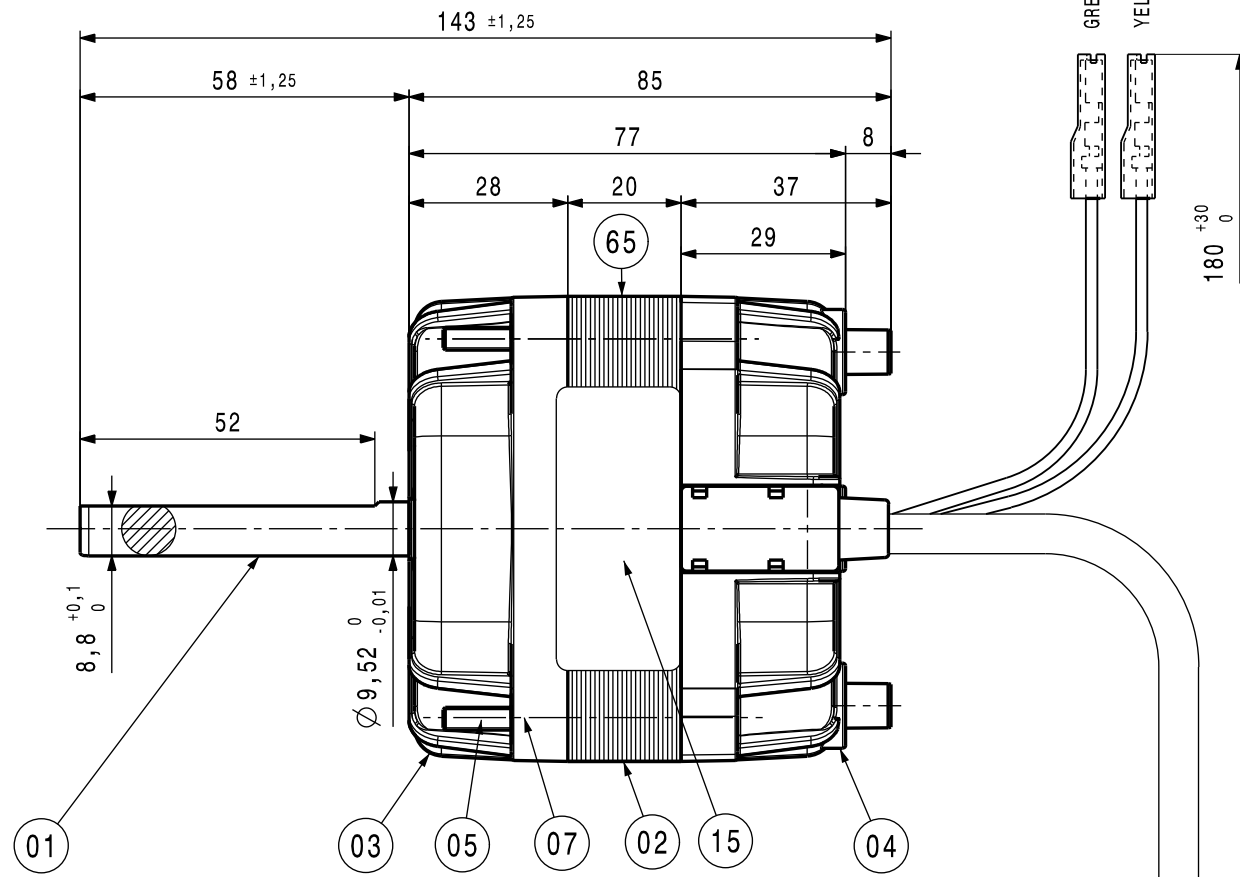
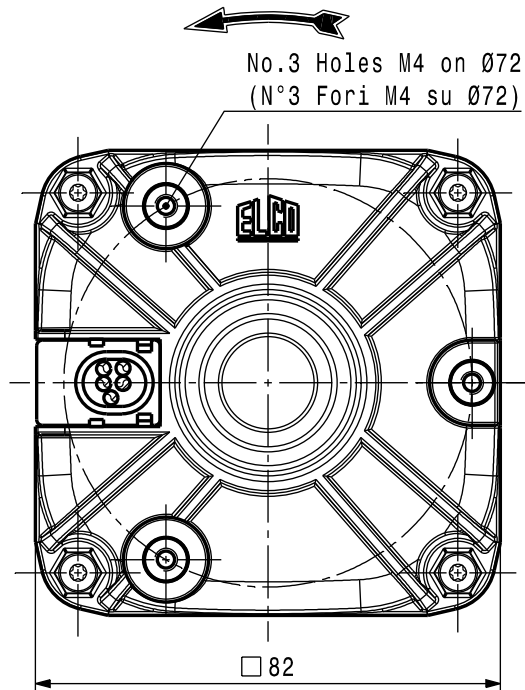

CODE: BTM41TB0257R  
TYPE: 1BT 20-20-1V NA

230V~ 50/60Hz 0,30A  
20/60W 1100Rpm C=3,15µF 450VL

← ROTATION  
DATA IP40

BLUE LINE  
BROWN LINE  
M  
YELLOW  
GREEN  
YELLOW/GREEN

Rel	Date	Description	Executer signature	Checked
B	20-01-2011	Changed motor shaft ( Modificato sporgenza albero era 38 )	Pedriani R.	Sirtori
A	02-02-2010	TOLTO FASTON MASCHIO AGGIUNTO FASTON FEMMINA SU CAVETTO GIALLO-VERDE	Pedriani R.	Sirtori
<b>MODIFICATIONS</b>				

For dim. without tolerance see standard UNI EN 22768-mK

Treatment . . . . .  
Material . . . . .

ELCO

Drawn Pedriani R.  
Date 27-10-2009  
Check T.Sirtori  
Scale ---

SINGLE PHASE MOTOR ( Motore Monofase )  
230V - 50/60Hz  
1BT 20-20-1V NA

Weight . . . . .  
Ref.No . . . . .

A3

Release B

**BTM41TB0257R**